



Pallet Truck

MT15

Capacity 1.5 t | Series 1133

Manoeuvrability in the tightest of spaces

- Compact chassis and good maneuverability for transports in narrow aisles
- Powered traction driving and lifting performance for loads of up to 1.5 t without effort
- Operator protection through long, low mounted tiller and low chassis
- 180 kg light weight truck can be used anywhere, even on mezzanines
- Lithium-ION battery allows intermediate charging and increases operating time

TECHNICAL DATA (According to VDI 2198)

Characteristics	1.1	Manufacturer		Linde
	1.2	Model		MT15
	1.2.a	Series		1133-03
	1.3	Power unit: Battery, diesel, gasoline, LPG		Battery
	1.4	Operation		Pedestrian
	1.5	Load capacity	Q (t)	1.5
	1.6	Load centre	c (mm)	600
	1.8	Axle centre to fork face	x (mm)	946/883
	1.9	Wheelbase	y (mm)	1200/1135
Weights	2.1	Service weight	(kg)	180
	2.2	Axle load with load, front/rear	(kg)	606/1074
	2.3	Axle load without load, front/rear	(kg)	145/35
Wheels/Tyres	3.1	Tyre: SE = (superelastic), P = (pneumatic)		PU/PU
	3.2	Tyre size, front	(mm)	Ø 210 × 70
	3.3	Tyre size, rear	(mm)	Ø 80 × 60 (Ø 74 × 88)
	3.5	Wheels, number front/rear (X = drive)		1x 2/4 (1x 2/2)
Dimensions	4.4	Lift	h3 (mm)	115
	4.9	Height of tiller arm in driving position, min/max	h14 (mm)	700/1200
	4.15	Fork height, lowered	h13 (mm)	80
	4.19	Overall length	l1 (mm)	1400
	4.20	Length to fork face	l2 (mm)	400
	4.21	Overall width	b1/b2 (mm)	620 (705)
	4.22	Fork dimensions s × e × l	s × e × l (mm)	50/150/1000
	4.25	Distance between fork-arms	b5 (mm)	540 (685)
	4.32	Ground clearance with load, center of wheelbase	m2 (mm)	30
	4.33	Aisle width, 1000 × 1200 mm pallet crosswise	Ast (mm)	2247
	4.34	Aisle width, 800 × 1200 along forks	Ast (mm)	2100
4.35	Turning radius	Wa (mm)	1390	
Performance	5.1	Travelling speed, with/without load	(km/h)	5/5.5
	5.2	Lifting speed, with/without load	(m/s)	0.028/0.031
	5.3	Lowering speed, with/without load	(m/s)	0.068/0.043
	5.8	Maximum gradeability, laden/unladen	(%)	8/20
	5.9	Acceleration time with/without load	(s)	10.78/9.88
	5.10	Service brake		Electric
Drive	6.1	Drive motor rating S2 60 min	(kW)	0.9
	6.2	Lift motor rating at S3 10 %	(kW)	0.8
	6.3	Battery according to DIN 43531/ 35/ 36 A, B, C, no		Li-ION
	6.4	Battery voltage, nominal capacity K5	(V/Ah)	48/20
	6.5	Battery weight	(kg)	10.5
	6.6	Energy consumption according to VDI cycle	(kWh/h)	0.239
Others	8.1	Type of drive control		DC
	8.4	Noise level	(dB(A))	< 70

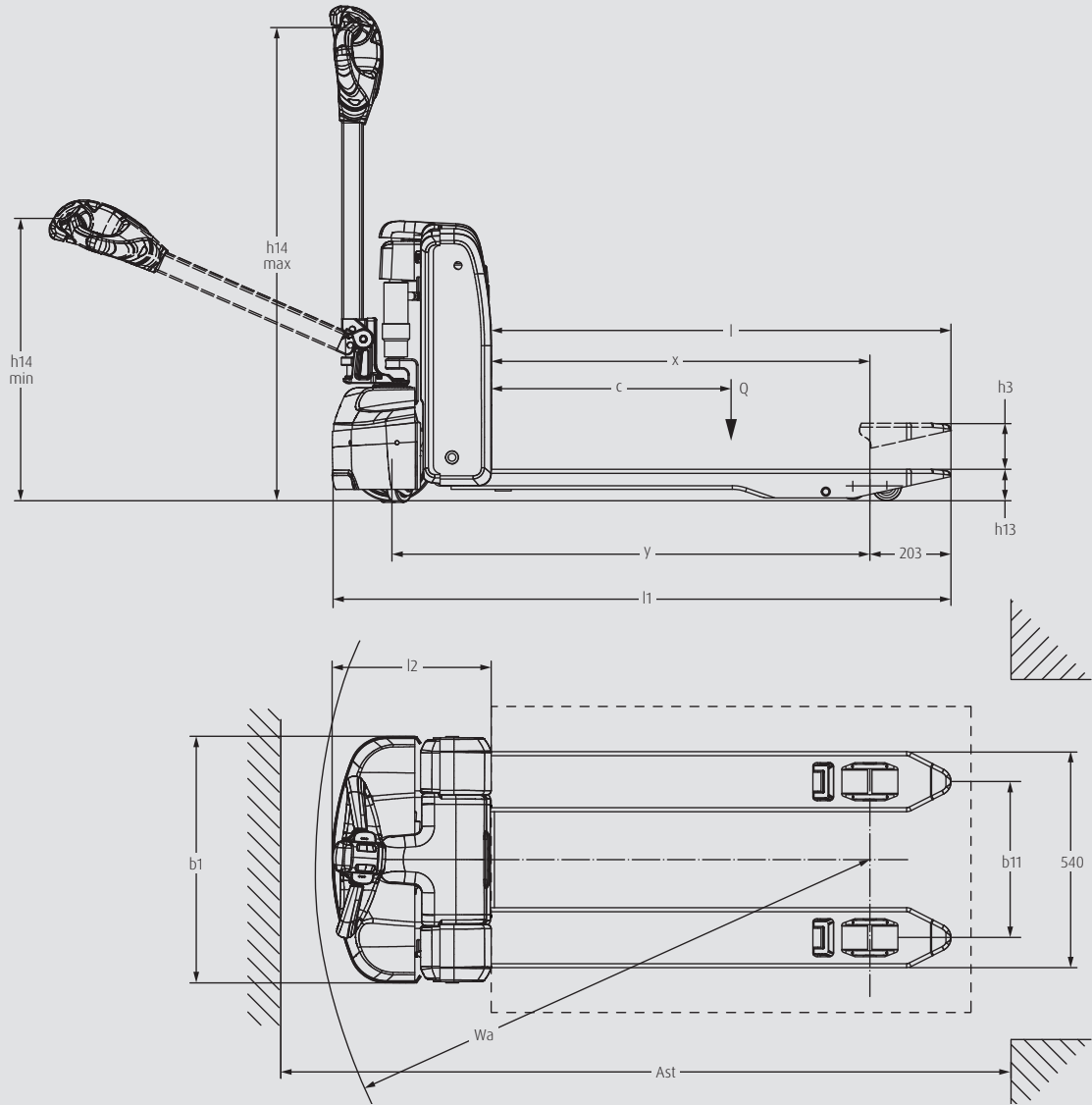



STANDARD AND OPTIONAL EQUIPMENT

Model/Equipment		MT15
Safety	Automatic parking brake	●
	Horn	●
	Safety switch on tiller head	●
	Robust metal protection covers	●
	Key switch	●
Service	CAN bus architecture	●
Operation / Load Handling	Creep speed	●
	Load backrest 1220 mm and 1520 mm	○
Workplace	Traction and lifted control from ergonomic tiller	●
	Multifunction display hour meter, maintenance indication, battery discharge indicator and internal fault code indication	●
Attachment / Forks	Fork width 520 mm, 540 mm and 685 mm	○
	Fork length up to 1300 mm	○
Axles and Tyres	Drive wheel polyurethane	●
	Drive wheel wet grip	○
	Tandem load wheels polyurethane	●
	Single load wheels polyurethane	○
Drive and Brake-system	0.9 kW DC motor (maintenance free)	●
	Electromechanical braking system	●
	Battery 48 V/20 Ah	●
	Battery 48 V/30 Ah	○
	Extra Li-ION battery (20 Ah/30 Ah)	○
	Inbuilt Li-ION 10 A Charger	●
External Li-ION 10 A Charger	○	

● Standard equipment

○ Optional equipment

CHARACTERISTICS



Long low mounted tiller ensures safety distance

Safety

- Long, low mounted tiller guarantees sufficient safety distance between operator and truck
- Low chassis prevents the driver's feet from getting under the truck
- Effective parking brake to hold the truck safely on slopes or on lorry tail lifts



All controls ergonomically integrated in the Linde tiller head

Ergonomics

- Ergonomic tiller head ensures precise and comfortable handling
- Creep speed function with vertical tiller arm improves maneuverability in confined spaces
- Built-in charger enables opportunity charging at any convenient power point for optimum uptime
- Charging time of only 2.5 hours



Easy plug and play Li-ION battery

Handling

- Compact chassis (L2: length including fork back of only 400 mm) ensures maneuverability
- Powered traction driving and lifting capacity facilitate transport of loads up to 1.5 tons
- 48 V 20 Ah or optional 30 Ah lithium-ion battery increases working time up to 3 hours
- 180 kg light weight truck can even be used on mezzanines



Intuitive multifunctional display

Service

- DC motor extends maintenance intervals and reduces service costs
- Multifunction display informs operator about truck status
- Battery management system ensures the quality and durability of the battery
- Service technicians can transfer and read out data to notebook via CAN bus connection
- All components are easily accessible

Subject to modification in the interest of progress. Illustrations and technical details could include options and not binding for actual constructions. All dimensions subject to usual tolerances.

Linde Material Handling

LDX Ltd. | 533 Halswell Junction Road | Hornby
Christchurch 8042 | Phone 0800 539 583 | www.idx.co.nz