

Standard and Optional Equipment

Standard Equipment

- The operator / truck interface
 - Long tiller arm with low mounting point made out of Grivory®
 - Exxtral® motor and battery cover
 - Soft fold back
 - End-of-stroke resistance
- Multifunction display with hourmeter, maintenance indication, battery discharge indicator and internal fault code indication
- AC motor
- Linde LAC controller
- CAN-Bus architecture
- Electromagnetic brake
- Automatic parking brake
- Cushion rubber drive wheel
- Tandem polyurethane load wheels
- Fork length: 1150 mm
- Width over forks: 560 mm
- Cold store protection to -10°C
- Vertical 2PzS battery change
- Horn
- Proportional speed control (T20)
- Creep speed control (T20)

Optional Equipment

- Drive wheels: polyurethane, non marking polyurethane
- Creep speed control (T16)
- Proportional speed control (T16)
- Side 2PzS battery change
- Alternative fork lengths and widths
- Fleet management LFMaccess and LFMbasic
- Cold store protection to -35°C
- Automatic battery watering system



Electric Pallet Truck T16, T20 1600, 2000kg

1151

Linde Material Handling

Linde

Safety

The lower chassis is rounded in shape and low to the ground protecting the operator's feet whilst the hand guards of the tiller head effectively shield his hands. The long tiller mounted low down on the chassis ensures ample safety clearance between operator and truck as well as keeping steering effort low.

Performance

The combination of a new AC motor and Linde LAC digital control makes these pallet trucks highly efficient. Operating parameters can be adjusted to match any application. When additional performance is needed, a booster effect automatically provides higher torque.

Comfort

All controls on the ergonomic tiller can be easily operated by either hand. An innovative creep speed button offers utmost manoeuvrability in confined areas. Proportional speed feature automatically alters traction speed in relation to the distance between truck and operator. Finished in tactile materials, these trucks deliver effortless, smooth load handling to deliver greater productivity.

Reliability

Despite their visual appeal, these pallet trucks are rugged and durable. Light, warm and robust at the same time the tiller out of Grivory® material ensures a highly resistant trucks interface. Exxtral®, launched for the motor cover gives no compromise regarding softness and sturdiness protecting the technical compartment. In addition, the fork tips which each withstands 2,000kg contribute to a long, trouble-free life.

Service

It is not just about the truck in operation: a maintenance-free AC motor maximises uptime reducing operating costs. All truck data is immediately and easy accessible to the service engineer via the CAN-Bus architecture. Fast, easy access to all internal components ensures service tasks are completed with a minimum of delay.

Features

Steering system

- Proportional speed control varies truck speed automatically in relation to tiller angle for safe, comfortable and productive operation
- A Creep speed button ensures high manoeuvrability in confined areas when operating at low speeds with the tiller in the upright position
- End-of-stroke resistance on the tiller avoids accidental, abrupt braking
- Soft tiller fold-back slows down the tiller when returning into upright position, avoiding tiller snapping on the motor cover



Working station & Display

- Wide, deep storage compartment for shrink wrap, pens, markers etc.
- Strong plastic Exxtral® motor and battery cover last the lifetime of the truck
- Multifunctional display as standard with hourmeter, maintenance indication, battery discharge indicator, fault code indication



Tiller & Tiller head

- The ergonomic Grivory® material ensures effortless operation
- Long tiller with low mounting point provides a large safety clearance between operator and chassis
- Wrap-around hand protection
- Comfortable controls, operable with either hand and gloves

Braking system

- Highly efficient electromagnetic brake applied by moving the tiller to fully up or down position
- Automatic braking on releasing traction butterfly or reversing direction
- Truck slows before coming to a stop, remaining under total control at all times

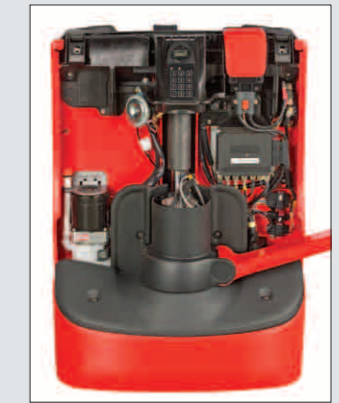

Maintenance and CAN-Bus architecture

- Zero maintenance, moisture and dust-proof AC motor
- CAN-Bus architecture enables fast, easy access to all truck data
- Individually adjustable parameters via diagnostic plug
- Rapid and convenient access to main components via front service panel

Subject to modification in the interests of progress, illustration and technical details not binding for actual constructions and may show the optional equipments.

Other Options Available on Request

Linde Material Handling

Linde

Technical Data

Characteristics	1.1	Manufacturer		Linde	Linde
	1.2	Model designation		T16	T20
	1.3	Power unit		Battery	
	1.4	Operation		Pedestrian	
	1.5	Load capacity	Q(kg)	1600	2000
	1.6	Load centre	c(mm)	600	600
	1.8	Axle centre to fork face	x(mm)	890/962 ¹⁾²⁾	890/962 ¹⁾²⁾
	1.9	Wheelbase	y(mm)	1312/1378 ¹⁾²⁾	1312/1378 ¹⁾²⁾
	Weights	2.1	Service weight	kg	485 ³⁾
2.2		Axle load with load, drive/load side	kg	725/1360 ³⁾	820/1665
2.3		Axle load without load drive/load side	kg	350/135 ³⁾	350/135 ³⁾
Wheels	3.1	Tyre, operator/load side		R+PU/PU ⁴⁾	
	3.2	Tyre size, drive side	mm	230x75	230x75
	3.3	Tyre size, load side	mm	2x85x100	2x85x100
	3.4	Auxiliary wheel, size	mm	125x40	125x40
	3.5	Wheels number, drive/load side (x=driven)		1X+2/4	
	3.6	Track width, drive side	mm	482 ¹⁾	482 ¹⁾
	3.7	Track width, load side	mm	355/395/515 ¹⁾	355/395/515 ¹⁾
Dimensions	4.4	Lift	h3(mm)	125 ¹⁾	125 ¹⁾
	4.9	Height of tiller arm in operation position, min./max.	h14(mm)	740/1208	740/1208
	4.15	Fork height, lowered	h13(mm)	85	85
	4.19	Overall length	l1(mm)	1725 ¹⁾⁶⁾	1725 ¹⁾⁶⁾
	4.20	Length to fork face	l2(mm)	575 ¹⁾⁶⁾	575 ¹⁾⁶⁾
	4.21	Overall width	b1/b2(mm)	720 ¹⁾	720 ¹⁾
	4.22	Fork dimensions	s/e/l(mm)	165x55x1150	165x55x1150
	4.25	Fork spread, min./max.	b5(mm)	520/560/680 ¹⁾	520/560/680 ¹⁾
	4.32	Ground clearance, center of wheelbase	m2(mm)	161/36	161/36
	4.33	Aisle width, 1000x1200mm pallet crosswise	Ast(mm)	1843 ⁵⁾⁶⁾	1823 ⁵⁾⁶⁾
4.34	Aisle width, 800x1200mm pallet lengthwise	Ast(mm)	2043 ⁵⁾⁶⁾	2023 ⁵⁾⁶⁾	
4.35	Turning radius	Wa(mm)	1535/1605 ²⁾⁵⁾⁶⁾	1515/1585 ²⁾⁵⁾⁶⁾	
Performances	5.1	Travel speed, with/without load	km/h	6.0/6.0	6.0/6.0
	5.2	Lift speed, with/without load	m/s	0.035/0.044	0.034/0.044
	5.3	Lower speed, with/without load	m/s	0.065/0.062	0.07/0.06
	5.8	Maximum climbing ability, with/without load	%	13/24	10/24
	5.9	Acceleration time, with/without load	s	7.4/6.4	7.6/6.4
Drive	6.1	Drive motor output (60 min. rating)	kw	1.2	1.2
	6.2	Lift motor output (15% rating)	kw	1.0	1.2
	6.3	Battery according to DIN 43 531/35/36A, B, C, no		DIN 43535/2PZs	DIN 43535/2PZs
	6.4	Battery voltage/rated capacity (5h)	V/Ah	24/220	24/220
	6.5	Battery weight (± 5%)	kg	212	212
	6.6	Power consumption according to VDI cycle	kWh/h	0.4	0.4
Others	8.1	Type of Drive control		LAC	LAC
	8.4	Sound level at driver's ear	dB(A)	<70	<70

Figures for standard version may vary when options equipment is fitted
 1) (± 5mm)
 2) Forks upraised / lowered
 3) (± 10%)
 4) Solid rubber+polyurethane/polyurethane
 5) With creep speed = tiller in vertical position
 6) See dimensions with alternative batteries

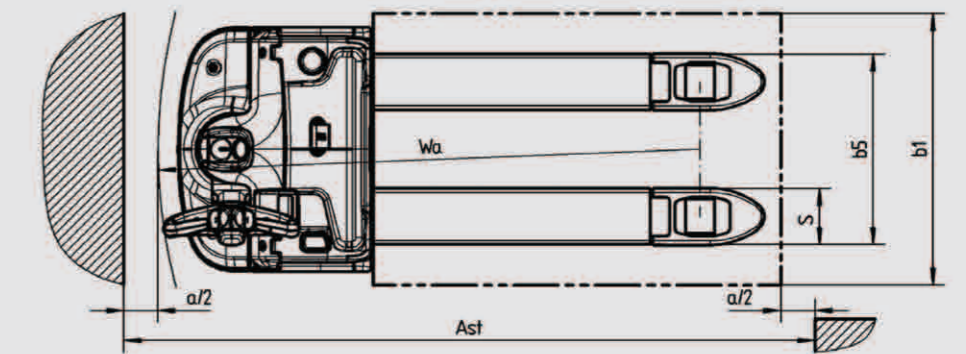
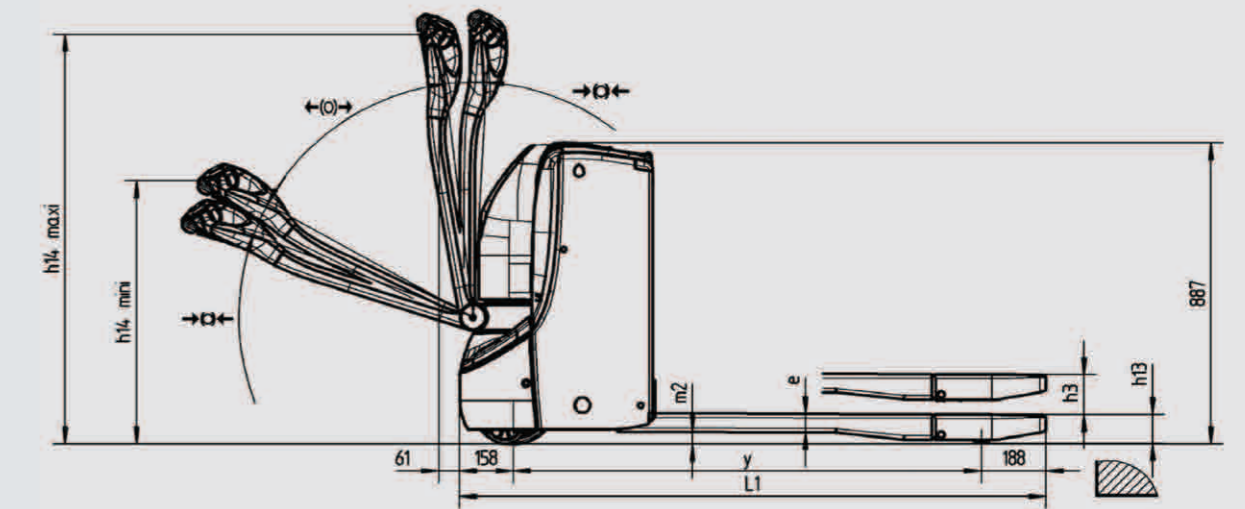
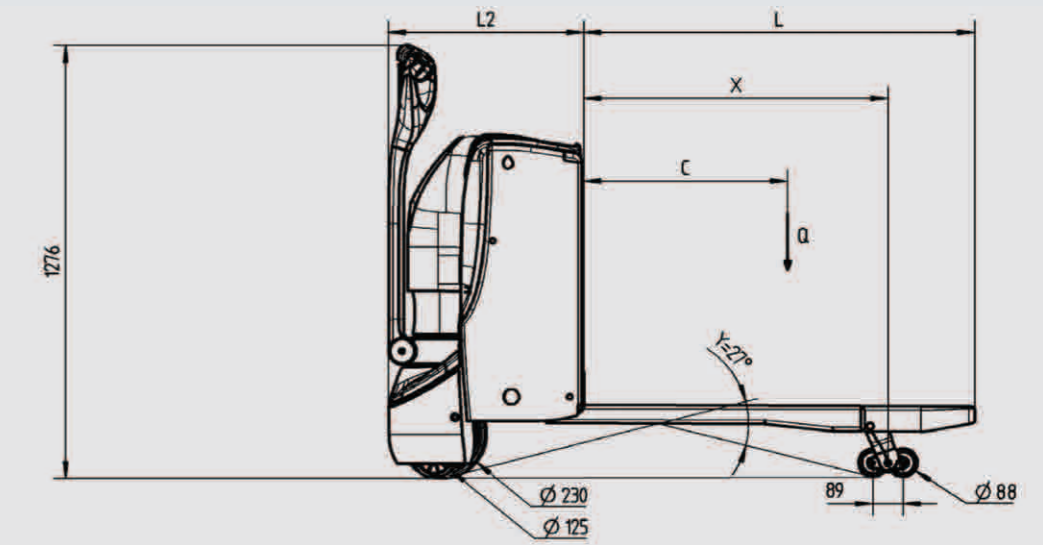

$$Ast = Wa - x + L6 + a$$

Safety clearance a = 200 mm